

VERMEIREN

Alya

USER MANUAL





Contents

Contents	1
Preface	2
1 Your product	3
1.1 Description	3
1.2 Accessories	3
2 Before use	4
2.1 Intended use	4
2.2 General safety instructions	4
2.3 Symbols on the scooter	5
2.4 Transport, folding and storing	5
2.5 Transport by transport handle (optional)	8
3 Using your scooter	9
3.1 First ride	9
3.2 Operating your scooter	9
3.3 Brake and free-wheel lever	12
3.4 Comfort adjustments	12
3.5 Charging and changing the battery	13
4 Maintenance	15
4.1 Cleaning	15
4.2 Reuse	15
4.3 Expected lifespan	15
4.4 End of use	16
5 Troubleshooting	17
6 Technical specifications	18



Preface

Congratulations! You are now owner of a Vermeiren scooter!

This scooter is made by qualified and committed personnel. It is designed and produced according to high quality standards guarded by Vermeiren.

Thanks for your trust in the products of Vermeiren. To support you on the use of this scooter and its operating options, this manual is offered. Please read it carefully; it will help you to get familiar with the operation, capabilities and limitations of your scooter.

If you still have questions after reading this manual, do not hesitate to contact your specialist dealer. He/she will be glad to help you on this subject.

Important note

To ensure your safety and to prolong the lifetime of your product, please take good care of it and have it checked and/serviced on regular base.

This manual reflects the latest product developments. Vermeiren has the right to implement changes to this type of product without being imposed to any obligation to adapt or replace similar products previously delivered.

Pictures of the product are used to clarify the instructions in this manual. Details of the depicted product may deviate from your product.

Information available

On our website <http://www.vermeiren.com/> you will always find the most recent version of following information. Please consult this website regularly since the printed version may be out of date.

Visually impaired people can download the electronic version of this manual and have it read out by means of a text-to-speech software application.



This user manual
For user and specialist dealer



User manual of battery charger.
For user and specialist dealer



Service manual for scooters
For specialist dealer



EC declaration of conformity

1 Your product

1.1 Description

The Alya scooter is easy to operate and is primarily intended for indoor use. It is foldable which makes it very compact to store or transport.

The following picture shows all parts that are relevant for the user/driver. In the operation and maintenance section, these parts are described if applicable.

i Before using your scooter, check the technical details and limits of intended use, see §6.



Figure 1 Important parts

- | | |
|----------------------|-----------------------------|
| 1. Handgrip | 7. Footplate |
| 2. Operating console | 8. Front wheel |
| 3. Steering column | 9. Rear wheel / drive wheel |
| 4. Seat | 10. Free-wheel lever |
| 5. Battery cover | 11. Identification plate |
| 6. Foot support | |

1.2 Accessories

The following accessories are available for Alya:

- Backrest
- Transport handle



2 Before use

2.1 Intended use

In this paragraph a brief description of the intended use of your scooter is given. Additionally, relevant warnings are added to the instructions in the other paragraphs. In this way we would like to make you aware of the possible misuse that may appear.

- This scooter is classified as a class A product and is intended primarily for indoor use.
- This scooter is designed and produced solely to transport one (1) person with a maximum weight of 115kg. It is not designed to transport goods or objects, or for any other use than the transport previously described.
- You should NOT use this scooter if you suffer from physical or mental impairments that may put you, or other people, in danger when driving the scooter, such as; visual impairment, mental disorder, hemiplegics or paraplegics. For this reason, consult your doctor first and make sure that your specialist dealer is informed about his advice.
- If applicable, use only accessories and spare parts approved by Vermeiren.
- Please read all technical details and limits of your scooter in chapter 6.
- The warranty on this product is based on normal use and maintenance as described in this manual. Damage to your product caused by improper use or lack of maintenance will cause the warranty to lapse.

2.2 General safety instructions

 CAUTION Risk of injuries and/or damage







Please read and follow the instructions in this manual. Otherwise you may get injured or your scooter may get damaged.

Keep the following general warnings in mind during use:

- Do not use your scooter if you under influence of alcohol, medicines or other substances that may influence your driving abilities.
- Be aware that some parts of your scooter may get very hot or cold due to ambient temperature, solar radiation, heating devices or due to the motor drive during the ride. Be careful when touching. Wear protective clothing if the weather is cold. After a ride, wait till the scooter/motor has cooled down.
- Before switching the scooter on, be aware of the environment/situation in which you are located. Adjust your speed to this before driving off. We advise you to use the slowest speed setting to drive indoors. For outdoor driving you can adjust the speed to a suitable speed at which you feel comfortable and safe.
- ALWAYS keep in mind that your scooter may stop suddenly due to a discharged battery or a protection that prevents your scooter from further damage. Also check the possible causes mentioned in chapter 5.
- Your scooter has been tested for electromagnetic compatibility and complies with the standard, see chapter 6. Nevertheless, sources of electromagnetic field may influence the driving performance of your scooter, such as the fields of mobile phones, power generators or high-power energy sources. On the other hand, the electronics of your scooter can affect other electronic appliances too, such as alarm systems of shops and automatic doors. We therefore advise you to check your scooter regularly for damage and wear, since these may enlarge the interference (see also chapter 4).
- Only drive on flat surfaces where all four wheels touch the ground and where there is sufficient contact to operate the scooter safely.
- Make sure that your hands, clothes, belts, buckles or jewellery don't get caught by wheels or other moving parts during use.

2.3 Symbols on the scooter

The symbols in following list are applicable to your scooter. Symbols can be found in the relevant ISO standard (ISO 7000, ISO 7001 and IEC 417).

	Maximum weight of the user in kg
	Indoor use only
	Maximum safe slope in ° (degrees).
	Maximum speed
	Type designation
	Risk of entrapment

2.4 Transport, folding and storing

 WARNING Risk of severe injuries

Do NOT use your scooter as seat in a vehicle, see the following symbol. The best way to transport your scooter is to fold and lift it (with help) in the vehicle. Secure the scooter to the vehicle to make sure that it won't move during cornering and that it won't be launched during sudden full braking.



 CAUTION Risk of damage or injuries

Transporting the scooter must be done with the free-wheel lever in coupled position to make sure that the brake is activated, see §3.3.

 CAUTION Risk of battery damage

When the scooter will be stored for a longer period, remove the battery and take maintenance into account during the storage period.





i When transporting the scooter by aircraft, disconnect the battery before handing the scooter over to airport personnel (see §3.5.2). The battery can remain in the scooter. Consult your airline for the correct handling procedure.

i When the scooter is parked or stored outdoors, use a cover to protect it against moisture.



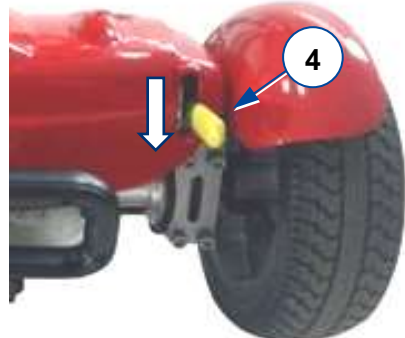

To transport your scooter over a small distance, put the scooter in free-wheel mode (see §3.3) and push it using the handles.

Read the instructions in §2.4.1 and §2.4.2 about folding and unfolding your scooter for transport purposes.

2.4.1 Unfolding your scooter

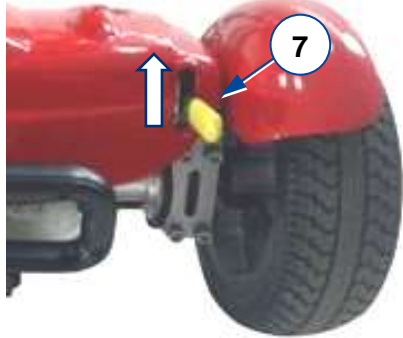
 <p>[1] Pull the yellow knob (1) on the bottom of the steering column and fold up the column until it clicks into place.</p>	 <p>[2] Pull the front frame (2) outwards until the footrest plates (3) are lying flat.</p>
 <p>[3] Holding the seat at the back, pull up the seat until it clicks into place.</p>	 <p>[4] If applicable, lock the backrest into place.</p>
 <p>[5] Raise the handgrips to a comfortable height to drive your scooter (see §3.4.1).</p>	 <p>[6] Put the free-wheel lever (4) in drive mode (§3.3). Insert the key and switch on your scooter (§3.2.1).</p>

2.4.2 Folding your scooter

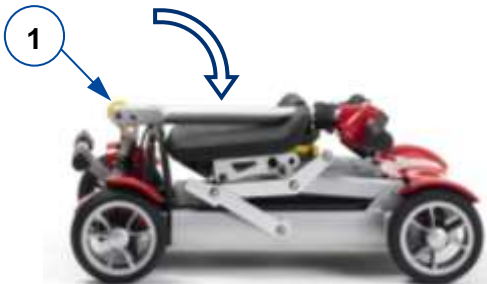
 <p>[1]</p> <p>Turn your scooter OFF and remove the key from the control panel (§3.2.1). Place the handgrips in their lowest position (§3.4.1).</p>	 <p>[2]</p> <p>Put the free-wheel lever (4) in free-wheel mode, see §3.3.</p>
 <p>[3]</p> <p>If applicable, unlock the backrest and fold it downwards.</p>	 <p>[4]</p> <p>Pull the yellow knob (5) beneath the seat backwards and fully lower the seat onto the frame.</p>
 <p>[5]</p> <p>Pull up the footrest plates (3) and slide the front part of the frame as far back as possible.</p>	 <p>[6]</p> <p>Pull the yellow knob (1) on the bottom of the steering column and fold the column down until it clicks into place.</p>



2.4.3 Using the transport handle (optional)

The scooter can be easily transported when folded by means of the transport handle.

1. Fold the scooter, see §2.4.2.
2. Using the handle (8) at the back, tilt the scooter to the front until it stands stable on the front wheels and foot supports.
3. Unlock the transport handle with the yellow lever (9).
4. Pull up the transport handle until it clicks into place. You can now pull the scooter forward with the handle.
5. When the transport handle is no longer needed, unlock it with the yellow lever (9) and slide the handle back down until it clicks into place.

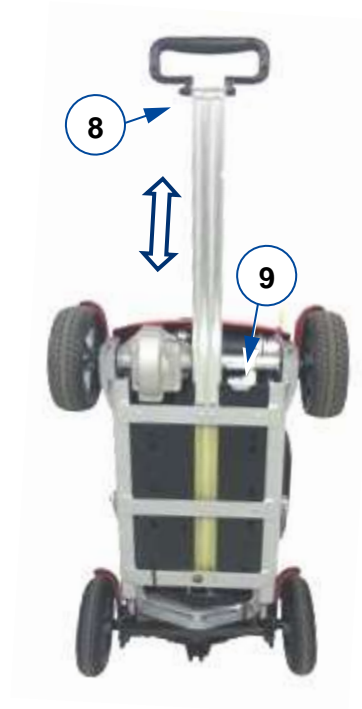

3 Using your scooter



WARNING

Risk of injuries

- First read previous chapters and inform yourself about the intended use. Do NOT use your scooter unless you have read and fully understood all instructions.
- In case of doubts or questions, do not hesitate to contact your local specialist dealer, your care provider or technical adviser to help you with this.

3.1 First ride



CAUTION

Risk of injuries and damage

- Make sure that your scooter is switched OFF when getting on and off.
 - Always unplug the battery charger from the scooter before starting to drive.
- i** Make sure you are familiar with the operation of your scooter before using it on crowded and possibly dangerous places. First exercise at a spacious, open area with little bystanders.
1. Make sure that:
 - the scooter is on a flat surface with all wheels touching the ground;
 - the battery is fully charged, see § 3.5;
 - the motor is coupled, see § 3.3;
 2. Switch your scooter on, see § 3.2.
 3. Turn the speed dial to lowest speed setting, see §3.2.2.
 4. Put both hands on the handgrips of the steering column.
 5. Slightly pull the speed lever to drive. Release the lever to stop. Repeat this a few times.
 6. If you feel confident enough, repeat this at a higher speed.
 7. Now try to turn, in forward and backward direction. Repeat this a few times.
 8. Make sure your scooter stands stable when ending the ride.
 9. Switch off the scooter and remove the key to protect against theft.

3.2 Operating your scooter



WARNING

Risk of injuries or damage

- Do NOT drive on slopes, obstacles, steps or kerbs larger than the size described in the technical specifications in chapter 6.
- Take the local road traffic law into consideration; it may differ per country.
- Since your scooter is not equipped with lighting, it is not suitable to drive on public roads at poor visibility (darkness, mist, twilight).
- Take the weather conditions into consideration. Avoid driving by moist weather, extreme heat, snow, black ice, freezing temperatures; see technical specifications in chapter 6.
- To prevent tipping over, try to drive with a large turning radius at corners and curves. Do not cut corners and don't drive with sharp bends. Try to drive straight in small passages to prevent getting entrapped.
- Do not lean too far to the left/right/front/back of the scooter to prevent tipping over. Please pay specially attention when you are negotiating slopes and obstacles.
- Be aware of other road users to whom your scooter may be an obstacle. Pay special attention when turning, reversing or driving backward. If you are not acquainted with driving backwards, first practice in an open area. Indicate the direction you intent to go before cornering.
- Keep the braking distance in mind, see also the technical specification in chapter 6. Be aware that the braking distance depends on speed, surface, weather conditions, slope and weight of the user.
- Pay attention if the road has holes or gaps that may cause entrapment of the wheels.



- The speed lever should be able to move freely at all times.

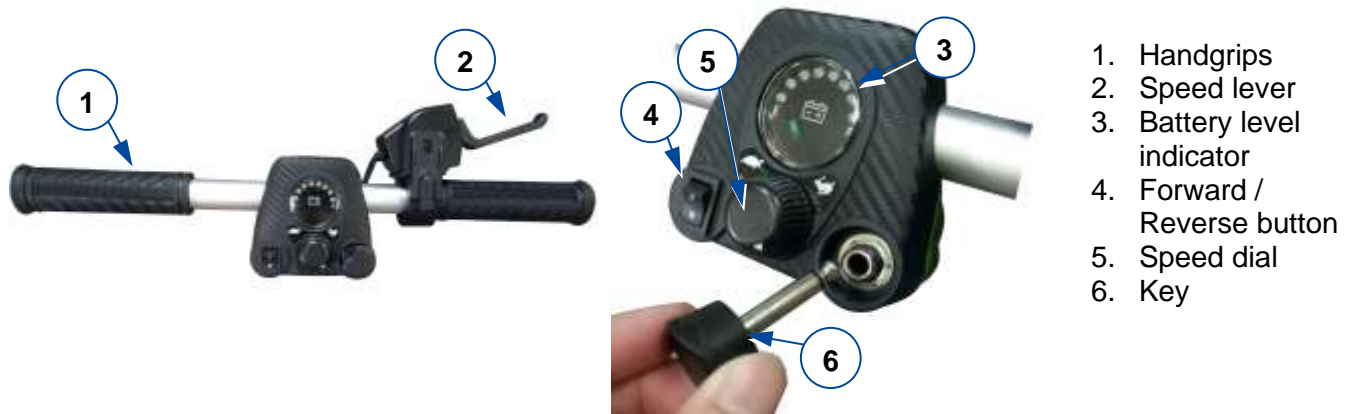

1. Handgrips
2. Speed lever
3. Battery level indicator
4. Forward / Reverse button
5. Speed dial
6. Key

3.2.1 Switching ON/OFF

Switching ON using the key (6)	Place the key (6) into the slot. The battery level indicator lights go on from left to right before indicating the battery status.
Switching OFF using the key (6)	Pull out the key (6) from the control panel. The lights of the battery level indicator extinguish.
Switching automatically OFF	The scooter will be switched off automatically if it hasn't been used for 30 minutes. To start the scooter again: <ul style="list-style-type: none"> • Remove the key (6). • Put the key back into place.

3.2.2 Driving

- i** This paragraph is a first acquaintance with driving your scooter. Read the complete manual first before you go for a ride.
- i** The surface of the controller gets slightly warm during use.

Speed lever (2)	To start or stop moving. The movement starts as soon as the lever is slightly pulled in a squeezing motion. The more the lever is pulled, the faster the scooter will move (up until the maximum speed setting). When the lever is release, the electromagnetic brake is applied. The scooter stops immediately.
Speed dial (5)	<ul style="list-style-type: none"> • Turn the speed dial (5) clockwise to increase the maximum speed setting. • Turn the speed dial counter clockwise to decrease the maximum speed setting.
Forward / Reverse button (4)	<ul style="list-style-type: none"> • Push the button upwards to move forwards. • Push the button downwards to move backwards.

3.2.3 Battery level indicator

The battery status lights will go on from left to right after switching on the scooter. When the battery is fully charged, all lights will be on. Using the scooter will decrease the battery charge, and some of the lights on the right will go out. The more lights are on, the more the battery is still charged.

The batteries need to be recharged if only the red lights on the left are on. Keep in mind that the scooter will automatically stop during the ride when battery charge becomes too low.

In case of any problems, the leftmost red light will start blinking. The number of blinks indicates the fault code. The meaning of this code can be found in §5.



3.2.4 Driving on slopes

 **WARNING** Risk of injuries

- Do not put your scooter in free-wheel mode on a slope. The scooter may start moving, causing injuries to you or bystanders.
- Do not turn when driving down a slope, since the weight of the scooter may cause tipping over.
- Make sure all four wheels touch the ground while driving up or down.

i When you stop on a slope, the brake will work automatically to prevent the scooter from running forward or backward.

Driving up

- Drive in a straight line and with higher speed on a slope, and lean slightly forward. When you drive in an angle or too slow, there is a risk of tipping over or falling.
- Never reverse on a slope.

Driving down

- Drive in a straight line (forward or backward) and with lower speed on a slope. When you drive in an angle or too fast, there is a risk of tipping over or falling.
- Lean slightly backward during a forward descent; lean slightly forward during a backward descent.

3.2.5 Coping with obstacles

 **WARNING** Risk of injuries by unexpected movement

- Do not use your scooter on an escalator.
- Always approach a kerb from the front.
- Make sure that all wheels make contact to the ground when driving up or down.

CAUTION Risk of damage

If necessary, take a short run-up to speed up the scooter to mount the obstacle or kerb. Prevent that you or your scooter has to cope with a large recoil.



3.3 Brake and free-wheel lever

 CAUTION Risk of injuries

- Only operate the free-wheel lever when your scooter is turned OFF!
- An attendant should operate the free-wheel lever if you have impaired mobility. NEVER operate it from sitting position.

i Make sure that the free-wheel lever is in its downward position BEFORE switching the scooter ON. Electromagnetic brakes do NOT function if the scooter is in free-wheel mode.

Your scooter is equipped with electromagnetic brakes. These brakes function automatically, only if free-wheel lever (7) is in downward position. In this situation, the brakes start braking if:

- the scooter is OFF;
- the scooter is ON and the speed lever is released.

Free-wheel lever (7):

- Push lever upward (position A) to put the scooter in free-wheel mode. The motor is disconnected and the scooter can be moved manually.
- Push lever downward (position B) to connect the motor to the drive. This should be done before starting the scooter.

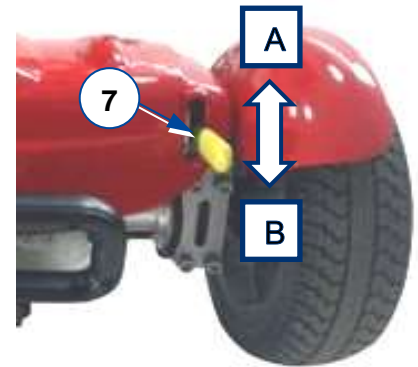

3.4 Comfort adjustments

i The following adjustments should be done before starting your scooter.

 CAUTION Risk of injuries or damage

- Make sure that your hands/fingers won't get entrapped during scooter adjustment.
- Make sure that no loose clothing can get caught by wheels or steering column.

3.4.1 Steering column

Adjust the height of the steering column with operating console so you can operate levers and buttons easily.

1. Loosen the lever (8) of the height adjustment.
2. Raise or lower the operating console with the hand grips.
3. Tighten the lever again.
4. Make sure that the height adjustment is well secured.



3.5 Charging and changing the battery

 **WARNING** Risk of injuries and damage due to fire

- Only use the battery charger delivered with the scooter. The use of any other charger may be dangerous (fire hazard).
- The battery charger is only intended to charge the batteries delivered with the scooter, not to charge any other batteries.
- Do not adapt any of the delivered parts, like cables, plugs or battery charger. Never open or change the battery or the connection points.
- Protect the battery and battery charger against flames, high and low temperatures (see chapter 6), moisture, sunshine, severe shocks (for example dropping). Do NOT use the battery if this has been the case.
- Charge the battery with the battery charger, indoors, in a well-ventilated area, out of children's reach.

CAUTION Risk of damage

- Battery self-discharge and the quiescent current of the connected users will drain the battery charge slowly. The battery may be irreversibly damaged if the battery is fully discharged. Therefore, make sure that the battery is charged on time (approximately once a month).
- Read the storage and maintenance instructions in § 4 and technical details in §6.
- Only disconnect the battery charger when the battery is fully charged.
- Do not charge batteries below 0°C. Move the battery to a warmer place and start charging.
- Keep the connection point for the battery charger free of dust and other contamination.
- In case of any problems whereby the battery cannot be charged according to following instructions, please contact your specialist dealer.
- Contact your specialist dealer for possible replacement.
- Protect the battery from large sources of electromagnetic radiation.
- Do not use an extension cord to charge the battery.

3.5.1 Charging the battery

i In case of any problems, contact your specialist dealer.

To charge the battery:

1. Switch the scooter OFF and remove the key.
2. FIRST connect the charger to a 230V AC power socket.
3. Open the cover of the charging point on the scooter (9).
4. Connect the charger to the scooter. Both the red and orange indicator lights on the charger light up.
5. Wait until the battery is fully loaded. The orange indicator light turns green.
6. Disconnect the charger from the scooter and slide the cover back in place.
7. Switch the scooter ON and check if all lights of the battery status indicator are on.
8. Remove the charger from the socket, let it cool down and store it in a dry location.



Depending on its condition, the battery will be charged after approximately 6 hours. Charging for a longer period won't harm the battery, but it is recommended not to charge for more than 24 consecutive hours. For daily use of your scooter we recommend to charge the batteries for approximately 10 hours after use.

The charging process can be stopped or started any time by following the instructions above.



3.5.2 Removing and replacing the battery

To remove the battery from the scooter:

1. Turn both locks (10) to align the blue markings. The battery cover (11) is now unlocked.
2. Carefully lift the battery cover to avoid damaging any wiring.
3. Disconnect the battery from all wires.
4. Take out the battery by pulling it off the Velcro straps.

To replace the battery:

1. Connect the battery to all wires.
2. Place the battery on the Velcro straps to secure it into place.
3. Close the battery cover (11). Make sure that no wires are pinched between the cover and frame.
4. Turn both locks (10) to align the red markings. The battery cover is now locked.
5. Switch on the scooter to check if everything is working properly.



4 Maintenance

i Regular care ensures that your scooter is preserved in a perfectly functional condition. For the maintenance manual, refer to the Vermeiren website: www.vermeiren.com.

 CAUTION Risk of injuries and damage

Repairs and replacements may only be undertaken by trained persons and only genuine replacement parts of Vermeiren should be used.

i The last page of this manual contains a registration form for the specialist dealer to record each service.

Before each use

Visually inspect the following points:

- Battery status: Charge the battery when necessary, see § 3.5.1.
- Condition of wheels/tyres: Correct pressure, profile, no damage.
- General condition.

Contact your specialist dealer for possible repairs or part replacements.

Every month

If your scooter is stored for a longer period, you still need to charge the batteries every month. For more information, see § 3.5.1.

Yearly or more often

Have your scooter inspected and serviced by your specialist dealer at least once a year, or more often. The minimum maintenance frequency depends on use and should therefore be commonly agreed upon with your specialist dealer.

If stored

Make sure that your scooter is stored in a dry environment to prevent mould from growing or the upholstery from being damaged. Disconnect the battery to prevent it from being damaged.

4.1 Cleaning

 CAUTION Risk of damage by moisture

- Keep the operating console clean and protect it from water and rain.
- Never use a hose or high-pressure cleaner to clean the scooter.

Wipe all rigid parts of the scooter with a damp cloth (not drenched). If necessary, use a mild soap, suitable for varnishes and synthetics.

The upholstery can be cleaned with lukewarm water and a mild soap. Do not use abrasive cleaning agents to clean.

Keep the ventilation openings of the battery charger clean and free of accumulated dust. Blow away the dust and clean the battery charger enclosure with a slightly moistened cloth, if required.

4.2 Reuse

Before each reuse, have the scooter disinfected, inspected and serviced according to the instructions in the maintenance manual.

4.3 Expected lifespan

The scooter is designed to have an average lifespan of 5 years. Depending on the frequency of use, driving circumstances and maintenance, the lifespan of your scooter will increase or decrease.



4.4 End of use

At end of life, you need to dispose your scooter according to the local environmental legislation. The best way to do so, is to disassemble the scooter to facilitate the transport of recyclable parts. Usually, batteries are collected separately.

5 Troubleshooting

Even if you use your scooter properly, a technical problem may occur despite this. In this case, contact your local specialist dealer.

 **WARNING** Risk of injuries and damage to the scooter

- NEVER attempt to repair your scooter yourself.
- For problems in the operating console you need to contact your specialist dealer. He/She will decide if the console needs to be reprogrammed.

The following symptoms may indicate a serious problem. Therefore always contact your specialist dealer if you spot any of following deviations:

- Strange sound;
- Frayed/damaged wiring harnesses;
- Cracked or broken connectors;
- Uneven tread wear at one of the tyres;
- Jerky movements;
- Scooter deflects to one side;
- Damaged or broken wheel assemblies;
- Scooter does not switch on;
- Scooter is powered, but does not move to the front or back.

In case of possible problem, a system code is displayed on the battery level indicator. This code can be found by counting the times that the leftmost red light will blink, see also §3.2.3. The following table summarises the possible system codes. Some problems can be solved by yourself. For all problems marked in grey, consult your specialist dealer.

Table 1: Troubleshooting

Code	Possible problem	Meaning
1	Low battery	Recharge the battery immediately.
2	Low battery	Recharge the battery. Check the battery and all associated connections and wiring. If the problem is not solved, contact your specialist dealer.
3	High battery	If traveling down a slope, stop / reduce your speed. Take less steep slopes.
4	Current limit time-out OR Controller too hot	Turn off the scooter, leave for a few minutes and turn back on. Check the motor and associated connections and wiring. If the problem is not solved, contact your specialist dealer.
5	Parking brake	Check the parking brake and associated connections and wiring. Contact your specialist dealer.
6	Drive inhibit	Disconnect the battery charger. OR Release the speed lever before switching on your scooter.
7	Speed pot	Check the throttle and speed pot, as well as all associated connections and wiring. Contact your specialist dealer.
8	Motor voltage	Check the motor and associated connections and wiring. Contact your specialist dealer.
9	Other	Check all connections and wiring. Contact your specialist dealer.



6 Technical specifications

The technical details below are only valid for this scooter, at standard settings and optimal ambient conditions. Take these details into account during use. The values are no longer applicable if your scooter has been modified, damaged or suffers from severe wear. Be aware that the driving performance is influenced by ambient temperature, humidity, slopes (driving up/down), type of surface and battery status.

Table 2: Technical specifications

Brand	Vermeiren
Type	Scooter, rear wheel drive, Class A
Model	Alya
Description	Dimensions
Max. weight of user	115 kg
Max. speed (driving forward)	6 km/h
Min. braking distance at max. speed	1490 mm
Action radius*	11,6 Ah battery: 12,8 km 17,4 Ah battery: 18,6 km
Maximum height of obstacle	40 mm
Maximum safe slope	6°
Minimum turning radius	1420 mm
Minimum width required to reverse	1500 mm
L x W x H Dimensions unfolded	905mm x 420mm x 710-910mm
L x W x H Dimensions folded	690mm x 420mm x 310mm
Total mass, battery included	11,6 Ah battery: 19,6 kg 17,4 Ah battery: 20,1 kg
Total mass, battery excluded	17,9 kg
Effective seat depth	230 mm
Effective seat width	330 mm
Seat surface height at front edge	370 mm
Height footplate	110 mm
Angle seat surface	0°
Motor	Nom. 180 Watt, electromagnetic brake
Battery	Li-ion battery 25,2 V – 11,6 Ah Li-ion battery 25,2 V – 17,4 Ah
Controller	Dynamic 50A
Protection class	IP X5
Battery charger	Input AC100-240V, Output DC29.4V, 2Amp
Protection class of battery charger	IPX2
Insulation class of battery charger	II
Max. sound level scooter motor	60 dB(5A)
EMC compatible according to	ISO 7176-21



Description	Dimensions
Ignitability of upholstery according to	EN 1021-2
Diameter rear wheels (number)	165 x 50 mm (2)
Diameter front wheels (number)	165 x 50 mm (2)
Suspension	N/A
Control (wig-wag)	Lever to start/stop movement
Operating console	Rotatable switch for speed control
Storage and use temperature	-10 °C to +50 °C
Humidity to store and use	30% ~ 70%
We reserve the right to introduce technical changes. Measurement tolerance ± 15 mm / 1,5 kg / 1,5°. * The theoretical action radius reduces if the scooter is frequently used on slopes, rough surfaces or to climb kerbs. The maximum driving distance is tested in ideal circumstances according to ISO 7176-4.	



Service registration form

This product (name):

was inspected (I), serviced (S), repaired (R) or disinfected (D):

By (stamp): Kind of work: I / S / R / D Date:	By (stamp): Kind of work: I / S / R / D Date:	By (stamp): Kind of work: I / S / R / D Date:
By (stamp): Kind of work: I / S / R / D Date:	By (stamp): Kind of work: I / S / R / D Date:	By (stamp): Kind of work: I / S / R / D Date:
By (stamp): Kind of work: I / S / R / D Date:	By (stamp): Kind of work: I / S / R / D Date:	By (stamp): Kind of work: I / S / R / D Date:
By (stamp): Kind of work: I / S / R / D Date:	By (stamp): Kind of work: I / S / R / D Date:	By (stamp): Kind of work: I / S / R / D Date:
By (stamp): Kind of work: I / S / R / D Date:	By (stamp): Kind of work: I / S / R / D Date:	By (stamp): Kind of work: I / S / R / D Date:



Vermeiren GROUP
Vermeirenplein 1 / 15
2920 Kalmthout
BE

website: www.vermeiren.com

Instructions for specialist dealer

This instruction manual is part and parcel of the product and must accompany every product sold.

Version: B, 2021-01

Basic UDI: 5415174 122124Alya MV

All rights reserved, including translation.

No part of this manual may be reproduced in any form what so ever (print, photocopy, microfilm or any other process) without written permission of the publisher, or processed, duplicated or distributed by using electronic systems.

© Vermeiren Group 2021